

HAMPRO® 140 Process plunger pump

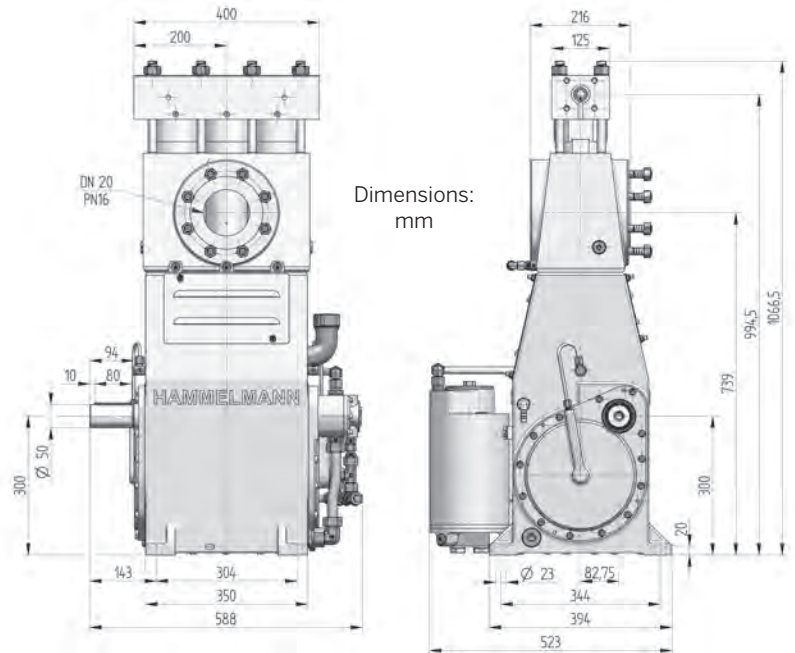

Hammelmann process pumps are built to operate at the continuous maximum duty stated in the performance parameters. Just compare the crankshaft speed, average plunger speed, plunger diameter and power rating.



Quality and reliability

- Crank section calculation by 'Finite element method' ensures long working life under continuous load
- Stainless steel pump head free of alternating stress
- Integral speed reduction gear
- Pressurised oil lubrication system with oil cooler/filter
- Bellows form hermetic seal between the suction chamber and crank section
- Large selection of materials available for different fluids
- Minimum crankshaft speed with external oilpump 32 r.p.m.

Features

- Power ratings up to 140 kW
- Vertical 3 cylinder design

Technical details HAMPRO® 140

Operating pressure	Flow rate
up to 3600 bar	up to 20,6 m ³ /h
Design	Weight
Vertical 3 cylinder design	~ 380 kg

Weight and dimensions refer to the pump only, without accessories. Detailed dimensional drawings and weights on request.

The bellow system is gastight.



Zero Emission



TA-Luft, (Clean Air) certified to VDI 2440

In the Zero Emission design the pumped fluid is hermetically sealed within the pump preventing leakage to atmosphere during operation.

Technical data, series HAMPRO® 140: Performance parameters (standard design)

HAM PRO®	Q** [l/min]	Q** [m³/h]	Required power rating [kW]			D [mm]	r.p.m.	
			45	90	140		n1	n2
			Operating pressure [bar]					
144	13	0,78	1660	3300	3600	17,5	1500	390
	15	0,90	1450	2900	3600		1417/1694	*440
	22	1,32	1150	2310	3550		1800/2150	560
	18	1,08	1270	2540		20	1500	390
	20	1,20	1100	2200	2800		1417/1694	*440
	27	1,62	880	1770	2800		1800/2150	560

Data

- Rod force: 88 kN
- Stroke: 55 mm
- Mean plunger speed at n2:

390 r.p.m. = 0,72 m/sec

440 r.p.m. = 0,81 m/sec

560 r.p.m. = 1,03 m/sec

143	30	1,80	810	1620		25	1500	390
	32	1,92	710	1430	1750		1417/1694	*440
	42	2,52	570	1130	1800		1800/2150	560
	37	2,2	640	1280		28	1500	390
	40	2,4	570	1140	1420		1417/1694	*440
	53	3,2	450	890	1430		1800/2150	560

Certificates

- Machine directive 2006/42/EG
- ATEX 2014/34/EG
- API 674
- TA-Luft (Clean Air)
- NORSOK M501
- NORSOK M650
- NACE MR0175

142	43	2,6	560	1130		30	1500	390
	47	2,8	490	990	1240		1417/1694	*440
	61	3,7	390	790	1240		1800/2150	560
	53	3,2	480	970		33	1500	390
	60	3,6	430	870	1030		1417/1694	*440
	77	4,6	340	680	1030		1800/2150	560
	59	3,5	410	830		35	1500	390
	65	3,9	360	730	910		1417/1694	*440
	84	5,0	290	580	910		1800/2150	560
	78	4,7	320	630		40	1500	390
	86	5,2	280	560	690		1417/1694	*440
	111	6,7	220	440	680		1800/2150	560
	100	6,0	250	500		45	1500	390
	109	6,5	220	440	550		1417/1694	*440
	142	8,5	170	350	530		1800/2150	560
	124	7,4	200	410		50	1500	390
	136	8,2	170	350	440		1417/1694	*440
	177	10,6	140	280	430		1800/2150	560
	150	9,0	170	340		55	1500	390
	165	9,9	140	290	370		1417/1694	*440
	214	12,8	120	230	350		1800/2150	560
	176	10,6	140	280		60	1500	390
	197	11,8	130	240	310		1417/1694	*440
	252	15,1	100	200	300		1800/2150	560
	207	12,4	120	240		65	1500	390
	232	13,9	100	210	260		1417/1694	*440
	296	17,8	80	160	250		1800/2150	560
	240	14,4	100	210		70	1500	390
	270	16,2	90	180	220		1417/1694	*440
	343	20,6	70	140	220		1800/2150	560

Standards

- DIN EN ISO 9001
- DIN EN ISO 14001
- DIN EN ISO 50001
- BS OHSAS 18001
- ASME-U
- Achilles
- EAC



Hammelmann plunger pumps convert 93 to 98 % of the shaft power to hydraulic energy.

**Data refer to the medium water (compressibility considered)

* Speed limit for continuous service according to API 674 – 6.3.1

D = Plunger diameter

n1 = Motor/Engine r.p.m.

n2 = Crankshaft r.p.m.